

A-A  
SCALE: 1 : 1

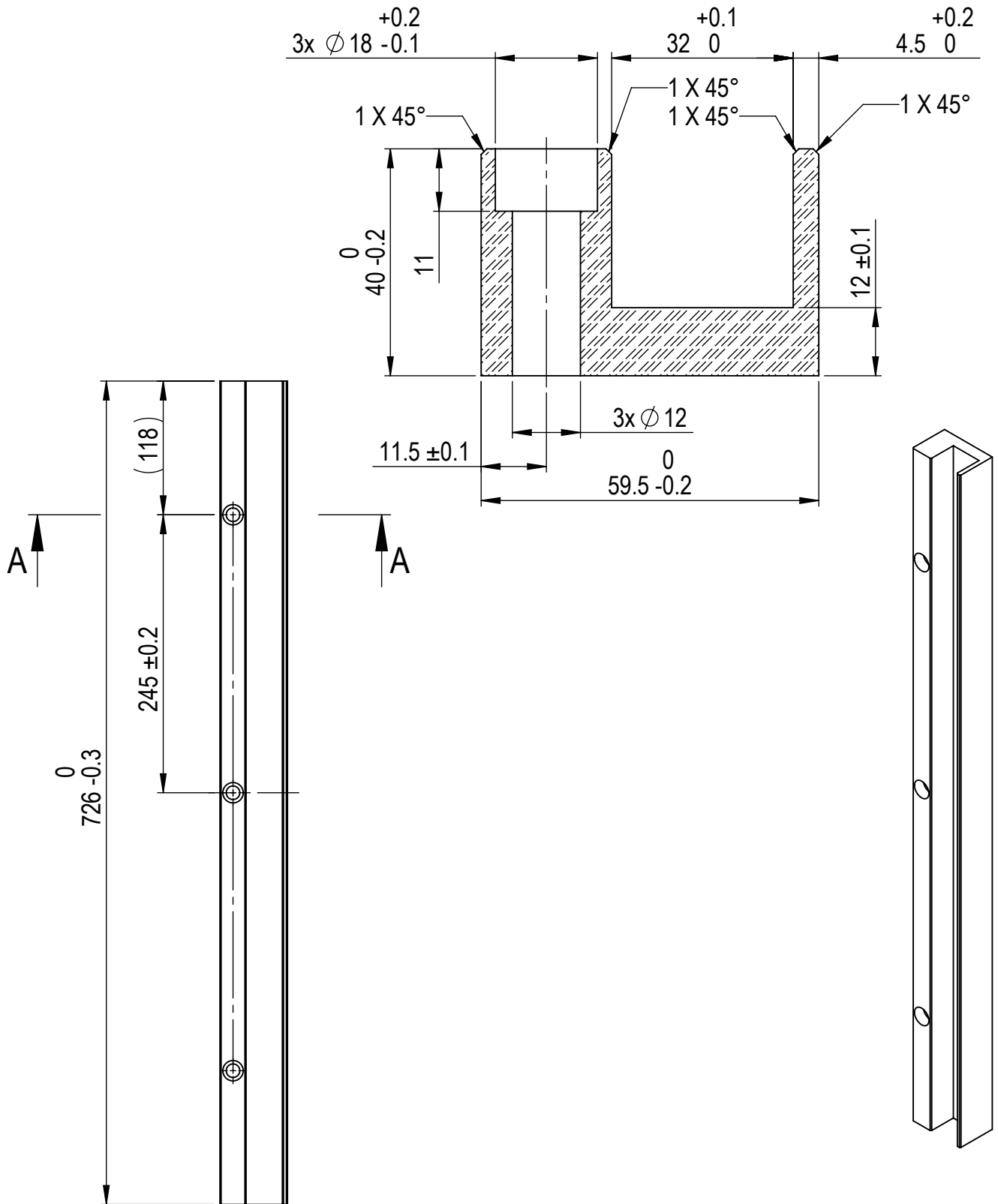

Other dimensions from .STEP file

	MATERIAL		WEIGHT	DEBURR AND BREAK SHARP EDGES		REVISION	DATE	
	6082 T6		2.855 Kg	DO NOT SCALE DRAWING			9/10/2025	
SURFACE PROTECTION		MACHINING	THERMAL CUTTING	WELDING		SCALE	FORMAT	
Anodizing ISO 7599:2010		ISO 2768 mK	ISO 9013 441	ISO 13920 BF		1:5	A4	
NAME		SIGNATURE	PART NO.					
Designed by D. Dislers			106-01107-02					
Drawn by K. Sulcs			DESCRIPTION				SHEET 1/1	
Technical ref.			Glass bracket W4					